

# 19" Rackmount-Kit HZ42, HZ43, HZ45, HZ46

## Assembly Instructions

English

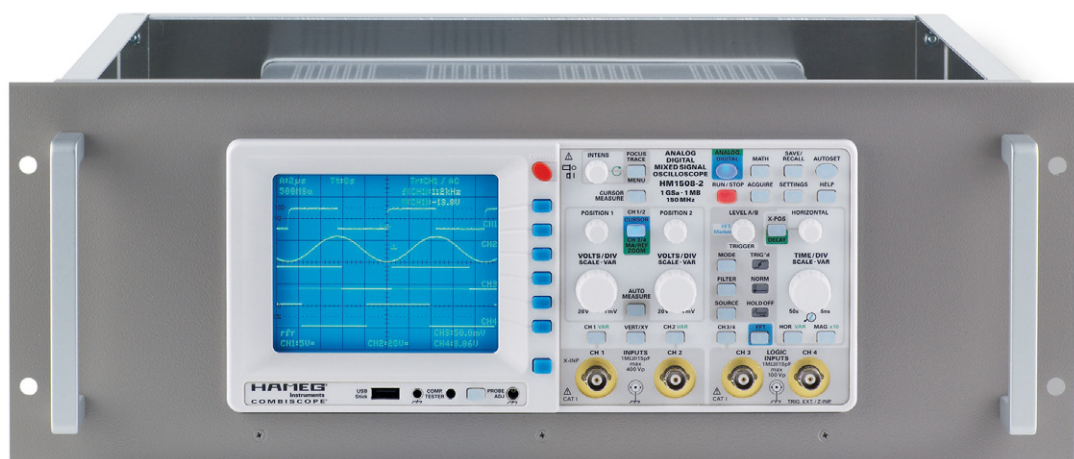

HZ42 / HZ43 Assembly Instructions

**HZ42:** 19"-Rackmount-kit 2HE (75 mm)  
for: HM7042-5, HM8001-2, Serie 8100, Serie  
HMF, HMP2020, HMP2030, HM8143

**HZ43:** 19"-Rackmount-kit 3HE (125 mm)  
for: HM2005, HM303-6, HM504-2, HM507,  
HM5510, HM5014-2, HM5530, HM6050-2,  
HM7044, HMP4030, HMP4040,

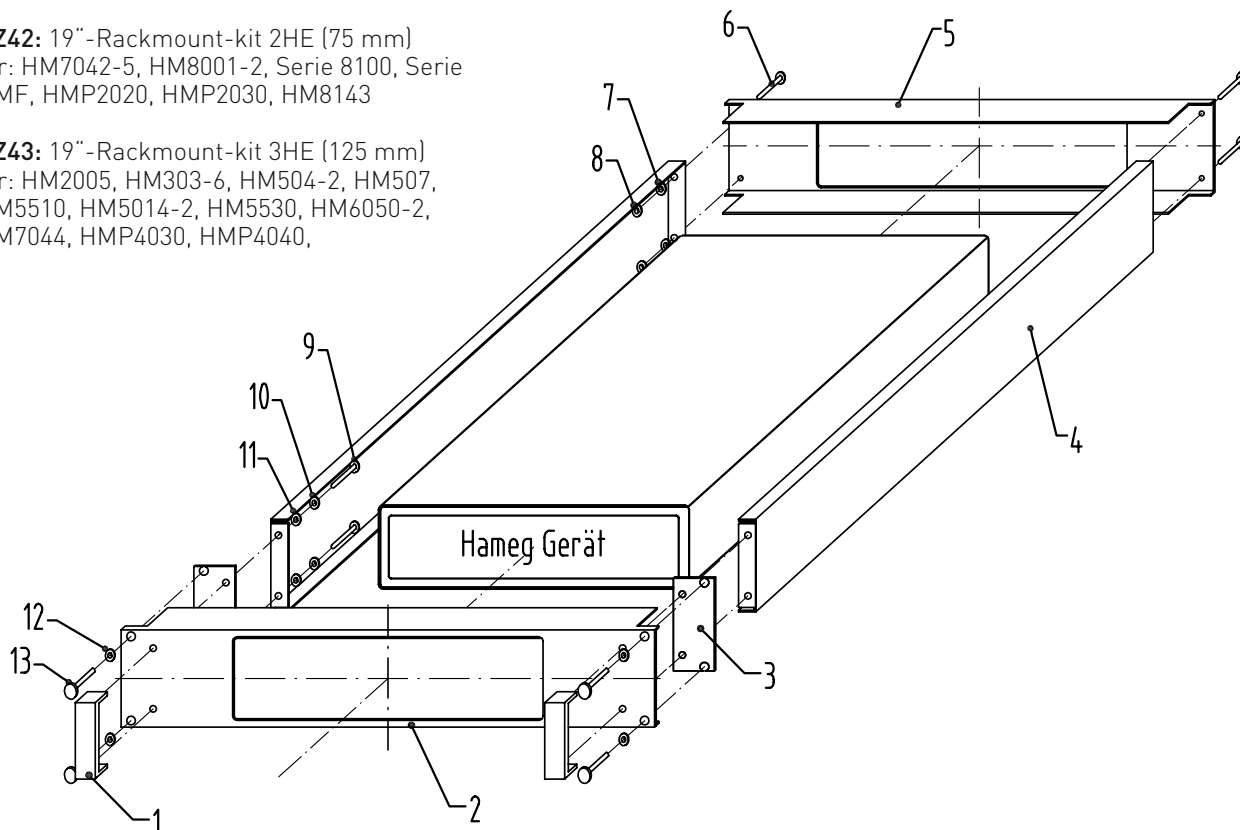

**Advice concerning the frame-feet of the instrument used in HZ42 and HZ43:**

The frame-feet of the instrument to be mounted will cause an overlap of the 2 Rack-Units (HZ42: 89mm) respective 3RU (HZ43 133mm) height if no space is used between 2 mounted instruments. In this case the removal of the frame-feet of the instrument (opening of the instrument, break the warranty seal, removal of 4 rivets) is necessary. We recommend to order the instrument(s) to be rack mounted to specify to be delivered without the feet. In this case the instrument(s) will be supplied with the feet removed in the factory, allowing the warranty seal to remain in place.

- |    |                     |                     |
|----|---------------------|---------------------|
| 1  | Handle              | (Griff)             |
| 2  | Front Panel         | (Frontplatte)       |
| 3  | Distance Plate      | (Distanzblech)      |
| 4  | Side Frame          | (Seitenteil)        |
| 5  | Rear Panel          | (Rückplatte)        |
| 6  | Flat headed Screw   | (Flachkopfschraube) |
| 7  | Toothed lock washer | (Zahnscheibe)       |
| 8  | Hex Nut             | (Sechskant Mutter)  |
| 9  | Flat headed Screw   | (Flachkopfschraube) |
| 10 | Toothed lock washer | (Zahnscheibe)       |
| 11 | Washer              | (Unterlegscheibe)   |
| 12 | Washer              | (Unterlegscheibe)   |
| 13 | Flat headed Screw   | (Flachkopfschraube) |

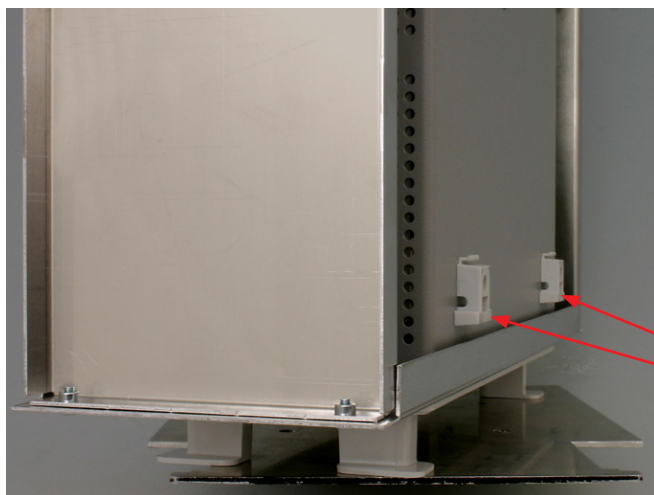

Mounted Frame-Feet exceed 2RU (=89mm HZ42) respective 3RU (=133m HZ43) height'

HZ45 Assembly Instructions

**HZ45:** 19"-Rackmount-kit 4HE (125 mm)  
 for: HM400, HM1000, HM1000-2, HM1008, HM1008-2,  
 HM1500, HM1500-2, HM1508, HM1508-2, HM2005-2,  
 HM2008

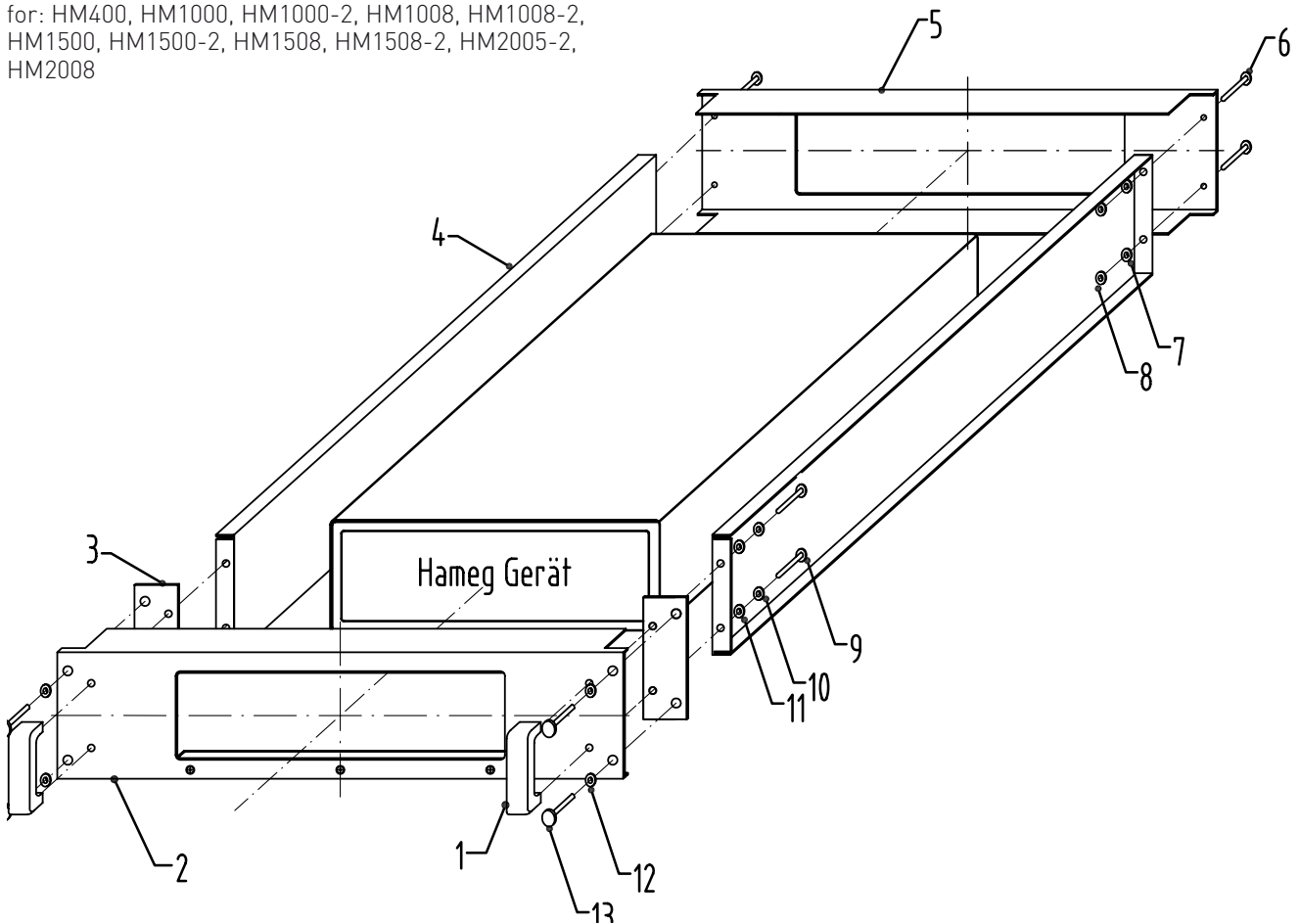

- |    |                     |                     |
|----|---------------------|---------------------|
| 1  | Handle              | (Griff)             |
| 2  | Front Panel         | (Frontplatte)       |
| 3  | Distance Plate      | (Distanzblech)      |
| 4  | Side Frame          | (Seitenteil)        |
| 5  | Rear Panel          | (Rückplatte)        |
| 6  | Flat headed Screw   | (Flachkopfschraube) |
| 7  | Toothed lock washer | (Zahnscheibe)       |
| 8  | Hex Nut             | (Sechskant Mutter)  |
| 9  | Flat headed Screw   | (Flachkopfschraube) |
| 10 | Toothed lock washer | (Zahnscheibe)       |
| 11 | Washer              | (Unterlegscheibe)   |
| 12 | Washer              | (Unterlegscheibe)   |
| 13 | Flat headed Screw   | (Flachkopfschraube) |

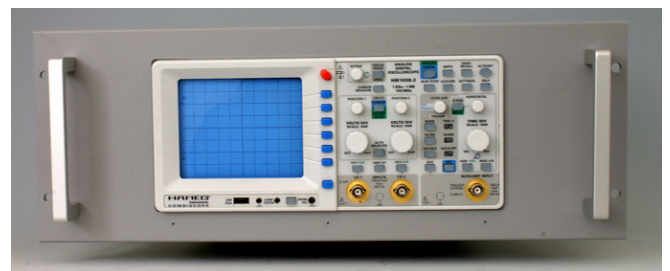

## HZ46 Assembly Instructions

**HZ46:** 19"-Rackmount-kit 4HE (175 mm)  
for series HMO und HMS

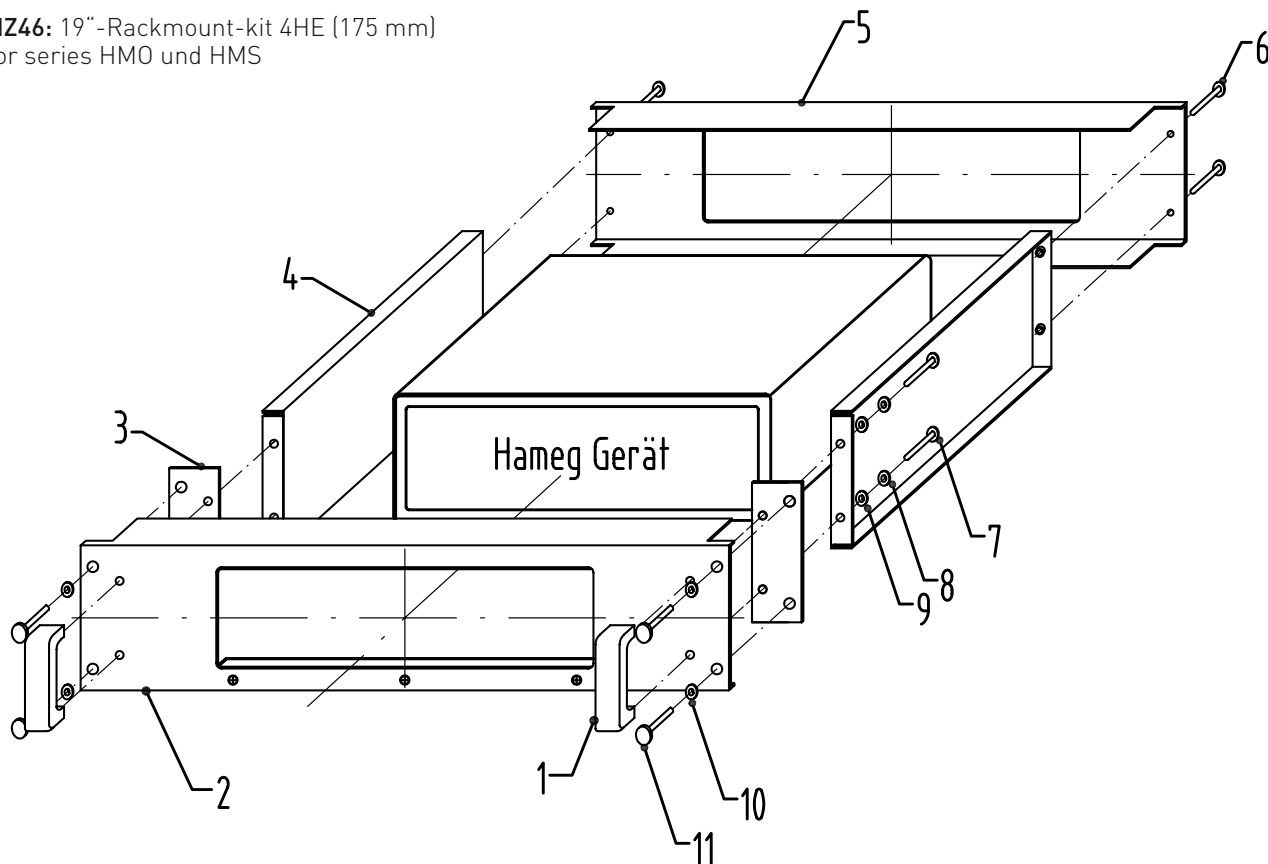

- |                        |                     |
|------------------------|---------------------|
| 1 Handle               | (Griff)             |
| 2 Front Panel          | (Frontplatte)       |
| 3 Distance Plate       | (Distanzblech)      |
| 4 Side Frame           | (Seitenteil)        |
| 5 Rear Panel           | (Rückplatte)        |
| 6 Flat headed Screw    | (Flachkopfschraube) |
| 7 Toothed lock washer  | (Zahnscheibe)       |
| 8 Hex Nut              | (Sechskant Mutter)  |
| 9 Flat headed Screw    | (Flachkopfschraube) |
| 10 Toothed lock washer | (Zahnscheibe)       |
| 11 Washer              | (Unterlegscheibe)   |
| 12 Washer              | (Unterlegscheibe)   |
| 13 Flat headed Screw   | (Flachkopfschraube) |

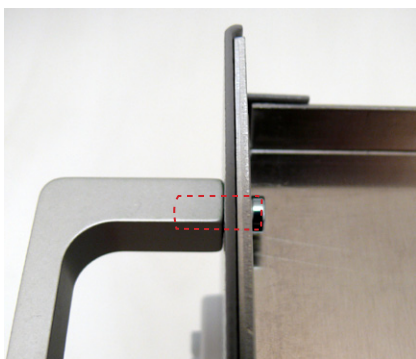

Different Perspectives

Front View HZ42/43

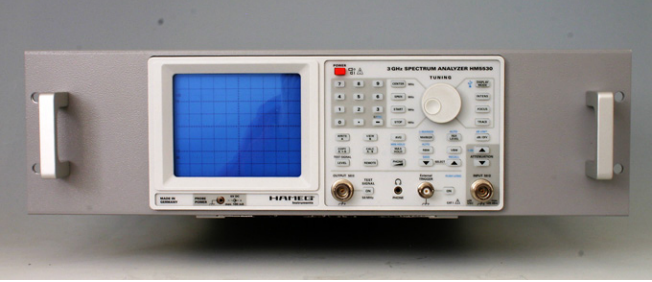

Rear View HZ42/43

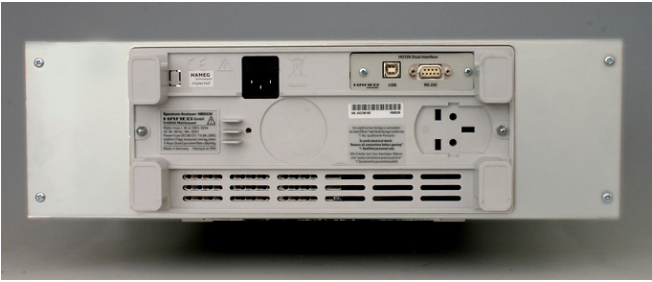

Bottom View HZ45



Side View (right)



Top View



Side View HZ46

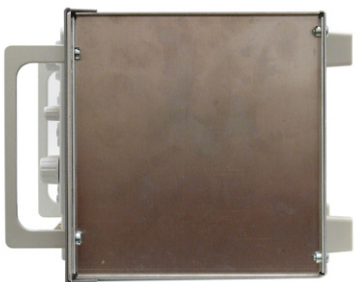

Rear View HZ46

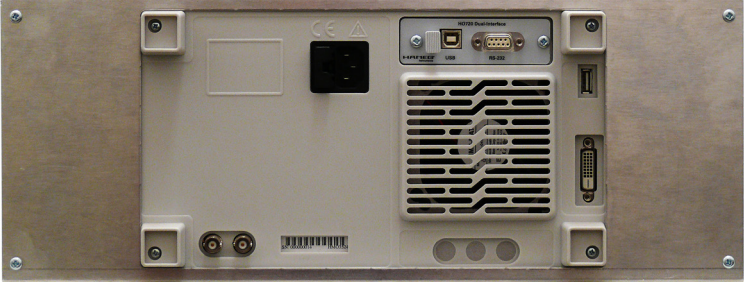

Oscilloscopes

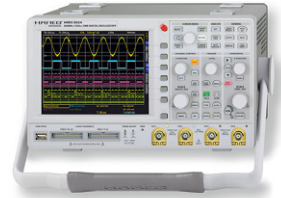

Spectrum Analyzer



Power Supplies



Modular System  
Series 8000



Programmable Instruments  
Series 8100

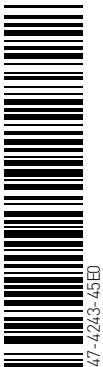

authorized dealer

[www.hameg.com](http://www.hameg.com)

Subject to change without notice  
47-4243-45E0 / 03032011

© HAMEG Instruments GmbH  
A Rohde & Schwarz Company



DQS-Zertifikation: DIN EN ISO 9001:2000  
Reg.-Nr.: 071040 QM

HAMEG Instruments GmbH  
Industriestraße 6  
D-63533 Mainhausen  
Tel +49 (0) 61 82 800-0  
Fax +49 (0) 61 82 800-100  
sales@hameg.de